

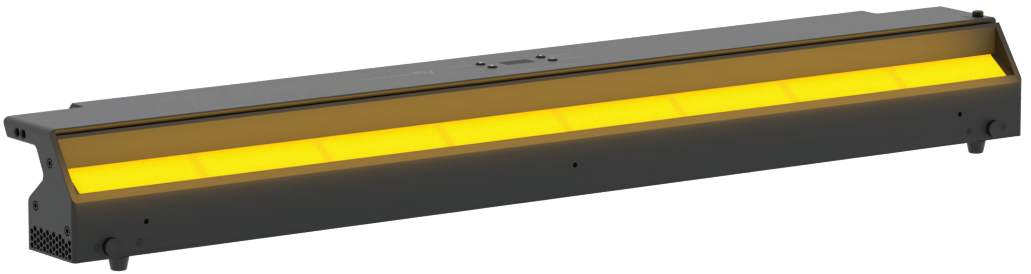

EclCyclorama 100

330 W linear soft CYC and flood light with
RGB + Warm White colour mixing



USER MANUAL

Thank you for choosing PROLIGHTS

Please note that every PROLIGHTS product has been designed in Italy to meet quality and performance requirements for professionals and designed and manufactured for the use and application as shown in this document.

Any other use, if not expressly indicated, could compromise the good condition/operation of the product and/or be a source of danger.

This product is meant for professional use. Therefore, commercial use of this equipment is subject to the respectively applicable national accident prevention rules and regulations.

Features, specifications and appearance are subject to change without notice. Music & Lights S.r.l. and all affiliated companies disclaim liability for any injury, damage, direct or indirect loss, consequential or economic loss or any other loss occasioned by the use of, inability to use or reliance on the information contained in this document.

Product user manual can be downloaded from the website www.prolights.it, or can be inquired to the official PROLIGHTS distributors of your territory (https://www.prolights.it/sales_network.html).

Scanning the below **QR Code**, you will access the download area of the product page, where you can find a broad set of always updated technical documentation: specifications, user manual, technical drawings, photometrics, personalities, fixture firmware updates.



Visit the download area
of the product page



The PROLIGHTS Logo, PROLIGHTS names and all other trademark in this document pertaining to PROLIGHTS services or PROLIGHTS product are trademarks OWNED or licensed by Music & Lights S.r.l., its affiliates, and subsidiaries. PROLIGHTS is a registered trademark by Music & Lights S.r.l. All right reserved. Music & Lights – Via A. Olivetti, snc - 04026 - Minturno (LT) ITALY.

INDEX

SAFETY INFORMATION	2
1 - PACKAGING	05
PACKAGE CONTENT	05
OPTIONAL ACCESSORIES	05
2 - TECHNICAL DRAWING	05
3 - INSTALLATION	06
MOUNTING	06
INTRODUCTION FOR INSTALLATION SET UP	07
INSTALLATION CONFIGURATIONS	07
4 - CONNECTION TO THE MAINS SUPPLY	08
5 - START UP	08
CONNECT AND DISCONNECT POWER FROM THE PRODUCT	08
6 - PRODUCT OVERVIEW	09
7 - DMX CONNECTION	10
CONNECTION OF THE CONTROL SIGNAL: DMX LINE	10
INSTRUCTIONS FOR A RELIABLE DMX CONNECTION	10
CONNECTION DAISY CHAIN	10
CONNECTION OF THE DMX LINE	10
CONSTRUCTION OF THE DMX TERMINATION	11
DMX ADDRESSING	11
ETHERNET CONNECTION	11
ETHERNET OPERATION	11
ETHERNET TO DMX OPERATIONS	12
OPERATION AS A WIRELESS TRANSMITTER	13
DMX TO WDMX (TX)	13
OPERATION AS A WIRELESS RECEIVER	114
WDMX TO DMX (RX)	14
8 - CONTROL PANEL	15
DISPLAY AND BUTTONS LAYOUT	15
9 - MENU STRUCTURE	16
10 - RDM FUNCTIONS	19
11 - DMX CHARTS	20
12 - ACCESSORIES INSTALLATION	24
THE POLE OPERATED YOKE (CODE ECLCYC100PO)	24
DIFFUSION FILTERS (CODE ECLCYCF)	25
BARN DOOR (CODE ECLCYCBD100)	26
HANGING BAR (CODE ECLCYCOHB)	27
13 - MAINTENANCE	28
MAINTENANCE AND CLEANING THE PRODUCT	28
REPLACING THE FUSE	28
VISUAL CHECK OF PRODUCT HOUSING	28
TROUBLESHOOTING	29

SAFETY INFORMATION



WARNING!

- Please read carefully the instruction reported in this section before installing, powering, operating or servicing the product and observe the indications also for its future handling.



This unit is not for household and residential use, only professional applications.



Connection to mains supply

- The Connection to the mains supply must be carried out by a qualified electrical installer.
- Use only AC supplies 100-240V 50-60 Hz, the fixture must be electrically connected to ground (earth).
- Select the cable cross section in according with the maximum current draw of the product and the possible number of products connected at the same power line.
- The AC mains power distribution circuit must be equipped with magnetic+residual current circuit breaker protection.
- Do not connect it to a dimmer system; doing so may damage the product.



Protection and Warning against electrical shock

- Do not remove any cover from the product, always disconnect the product from AC power before servicing.
- Ensure that the fixture is electrically connected to ground (earth). And use only a source of AC power that complies with local building and electrical codes and has both overload and ground-fault (earth-fault) protection.
- Before using the fixture, check that all power distribution equipment and cables are in perfect condition and rated for the current requirements of all connected devices.
- Isolate the fixture from power immediately if the power plug or any seal, cover, cable, or other components are damaged, defective, deformed or showing signs of overheating.
- Do not reapply power until repairs have been completed.
- Refer any service operation not described in this manual to PROLIGHTS Service team or an authorized PROLIGHTS service center.



Installation

- Make sure that all visible parts of the product are in good visible condition before its use or installation.
- Make sure the point of anchorage is stable before positioning the projector.
- When suspending the fixture above ground level, secure it against failure of primary attachments by attaching a safety cable that is approved as a safety attachment for the weight of the fixture to the attachment point on the main frame of the product. In case the safety cable, enter in action, it needs to be replaced with a new one.
- Install the product only in well ventilated places.
- For non temporary installations, ensure that the fixture is securely fastened to a load-bearing surface with suitable corrosionresistant hardware.
- For a temporary installation with clamps, ensure that the quarter-turn fastener and/or screws are turned fully, and secured with a suitable safety cable.



Minimum distance of illuminated objects

- The projector needs to be positioned so that the objects hit by the beam of light are at least 0.5 meters (1.64 ft) from the lens of the projector.

T_a45°C

Max operating ambient temperature (T_a)

- Do not operate the fixture if the ambient temperature (T_a) exceeds 45 °C (113 °F).

T_a-10°C

Minimum operating ambient temperature (T_a)

- Do not operate the fixture if the ambient temperature (T_a) is below -10 °C (14 °F).



Protection from burns and fire

- The exterior of the fixture becomes hot during use. Avoid contact by persons and materials.
- Ensure that there is free and unobstructed airflow around the fixture.
- Keep flammable materials well away from the fixture
- Do not expose the front glass to sunlight or any other strong light source from any angle. Lenses can focus the sun's rays inside the fixture, creating a potential fire hazard.
- Do not attempt to bypass thermostatic switches or fuses.



Indoor use

- This product is designed for indoor and dry environments.
- Do not use in wet location and do not expose the fixture to rain or moisture.
- Never use the fixture in places subject to vibrations or bumps.
- Make certain that no inflammable liquids, water or metal objects enter the fixture.
- Excessive dust, smoke fluid, and particle build up degrades performance, causes overheating and will damage the fixture.
- Damages caused by inadequate cleaning or maintenance are not covered by the product warranty.

T_c70°C

Temperature of the external surface

- The surface of the fixture can reach up to 70 °C (158 °F) during operation. Avoid contact with people and materials.



Maintenance

- Warning! Disconnect the fixture from AC mains power and allow to cool for at least 10 minutes before handling.
- Only technicians who are authorized by PROLIGHTS or Authorised service partners are permitted to open the fixture.
- Users may carry out external cleaning, following the warnings and instructions provided, but any service operation not described in this manual must be referred to a qualified service technician.
- Important! Excessive dust, smoke fluid, and particle build up degrades performance, causes overheating and will damage the fixture. Damages caused by inadequate cleaning or maintenance is not covered by the product warranty.



Photobiological safety

- This device emits potentially dangerous optical radiation and is identified in the category of Risk Group 2 according to EN 62471.

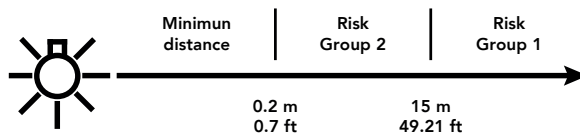



Do not stare at the operating light source

- Do not look directly at the LED source during operation. It can be harmful to the eyes and skin.
- During Installation, operation and maintenance, be prepared for the fixture to light and move suddenly when connected to power.
- The device should be positioned so that prolonged staring into the luminaire at a distance closer than 15 m (49.21 ft) is not expected.



Disposal

- This product is supplied in compliance with European Directive 2012/19/EU – Waste Electrical and Electronic Equipment(WEEE). To preserve the environment please dispose/ recycle this product at the end of its life according to the local regulation.



The product contains a lithium ion battery

- Don't throw the unit into the garbage at the end of its lifetime.
- Make sure to dispose according to your local ordinances and/or regulations, to avoid polluting the environment!
- The packaging is recyclable and can be disposed.



The products to which this manual refers comply with:

- 2014/35/EU - Safety of electrical equipment supplied at low voltage (LVD).
- 2014/30/EU - Electromagnetic Compatibility (EMC).
- 2011/65/EU - Restriction of the use of certain hazardous substances (RoHS).
- 2014/53/EU - Radio Equipment Directive (RED).



The products to which this manual refers comply with:

- UL 1573 + CSA C22.2 No. 166 - Stage and Studio Luminaires and Connector Strips.
- UL 1012 + CSA C22.2 No. 107.1 - Standard for power units other than class 2.



FCC Compliance:

- This device complies with Part 15 of the FCC Rules. Operation is subject to the following two conditions:
 1. This device may not cause harmful interference, and
 2. This device must accept any interference received, including interference that may cause undesired operation.



Other approvals

- The product meets the safety requirements of the certification procedures of the market in which it is placed and sold.



1 - PACKAGING

PACKAGE CONTENT

- 1x ECLCYC100;
- 1x 1,5 meters power cable (BARE END - SEETRONIC IP65 power connector);
- 2x OS25;
- User manual.

OPTIONAL ACCESSORIES

- WSBBR512G6: blackBox R-512 G6 receiver 512Ch, 2.45GHz,DMX&RDM,Bluetooth,G3,G4,G4S,G5,CRMX;
- WSBBR512G5: blackBox R-512 G5 receiver 512Ch, 2.45GHz & 5.8GHz, DMX/RDM optional;
- WSBBF1G6: blackBox F-1 G6 transrec, 512ch, 2.45GHz, DMX&RDM,Bluetooth,G3,G4,G4S, G5, CRMX;
- WSBBF1G5: blackBox F-1 G5 transmitter, 2,45GHz & 5.2/5,8 GHz, DMX/RDM, 512Ch;
- TOUR53415L03: dmx cable HC5340. CANC5MXX XLR 5p->CANC5FXX XLR (f) 5p, L.3m;
- FCLECLCYC: Flightcase for 4 pcs of ECLCYC100 or 8 pcs ECLCYC050 divided on two layers;
- ECLCYCBD100: Upper and lower barn door for adjust the light beam for ECLCYC100;
- ECLCYC100PO: Pole operated aluminium yoke bracket for pan/tilt for ECLCYC100;
- ECLCYCF40L100: Light diffuser filter for ECLCYC series projectors, 40°, lenght 100 cm;
- ECLCYCF1060L100: Light diffuser filter for ECLCYC series projectors, 10°x60°, lenght 100 cm;
- ECLCYCF3060L100: Light diffuser filter for ECLCYC series projectors, 30°x60°, lenght 100 cm;
- ECLCYCOHB: Orientable hanging bar for ECLCYC series projectors;
- C6040: Heavy-load aluminum clamp,250kg load, 48-51mm tubes, M10 bolt inc.;
- OS25: Quick-Lock omega bracket;
- UPBOX1U: Firmware uploader kit, USB IN, 3-pin XLR DMX OUT, USB OUT;
- RSR0603A/B: Steel security cable for hanging bodies, inox steel shackle, L=60 cm, silver/black.

2 - TECHNICAL DRAWING

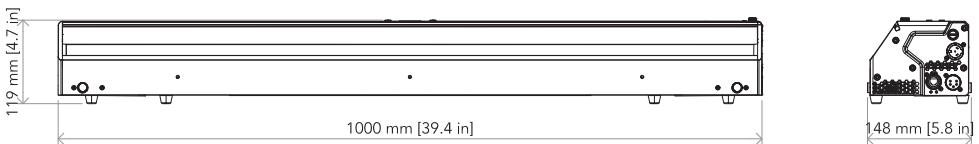

Weight: 9.6 kg - 21.16 lbs

Dimensions are in mm / in - Fig.1

3 - INSTALLATION

MOUNTING

Check that the supporting structure can safely bear the weight of all installed fixtures, clamps, cables, auxiliary equipment, etc. and complies with locally applicable regulations.

When suspending the fixture above ground level, secure it against failure of primary attachments by attaching a safety wire that is approved as a safety attachment for the weight of the fixture to an anchor point on the product main frame.

Do not use removable parts or weak anchors for secondary attachment.

Warning! When clamping the fixture to a truss or other structure at any angle, use clamps of half-coupler type. Do not use any type of clamp that does not completely encircle the structure when fastened.

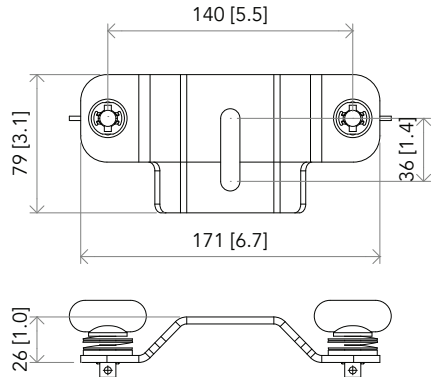
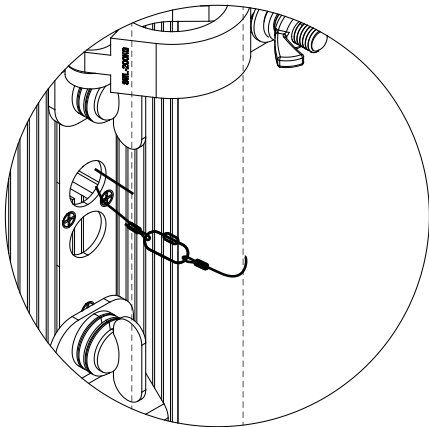
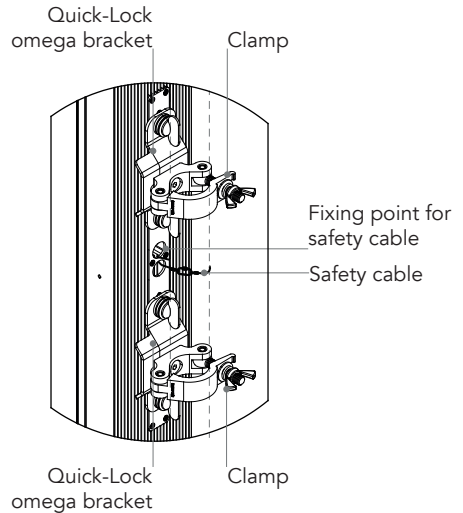
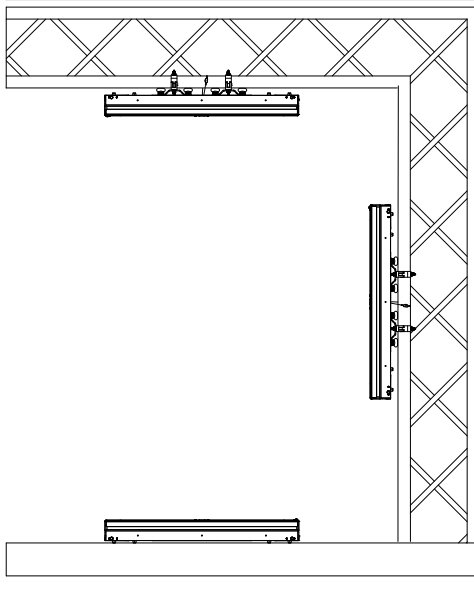

Fig.2

INTRODUCTION FOR INSTALLATION SET UP

The ECLCYC100 is an asymmetrical fixture that has been designed for application as CYC light and floodlight being able to be placed both at the front or at the end of the stage. Its soft and wide optics features a beam angle of 80° horizontal x 40° Vertical (asymmetry of 25° on the vertical), making this fixture flexible and effective to illuminate walls, sets and cyclorama uniformly with and even wash with a perfect blending of colours in multiple and flexible configurations.

The ECLCYC100 ensures good light distribution from 1m up to 3m installation distance from the CYC wall, and it can be installed placing fixtures next each other in a continuous line or with a clearance of up to 3 meter without hard edges or dark gaps, even when illuminating curved canvas.

INSTALLATION CONFIGURATIONS

ECLCYC100 can be installed at the bottom, top or both top+bottom depending of the desired effect (eveness or color gradient on the cyclorama).

One of the key aspects of the ECLCYC100 is its flexibility, and this document will shows how the fixture will be have at different distance from the CYC wall, and how it performs when combines in top+bottom configuration.

The ECLCYC100 is equipped with on board adjustable foot to regulate the tilt for the fixture focusing. The Tilt adjustment has a range of $\pm 8^\circ$. For distances from 1 to 1,5m the Tilt should adjusted at $+8^\circ$, for distances more than 3m the Tilt should be adjusted at -8° .

RELATION BETWEEN VERTICAL COVERAGE AND DISTANCE FROM THE CYC WALL

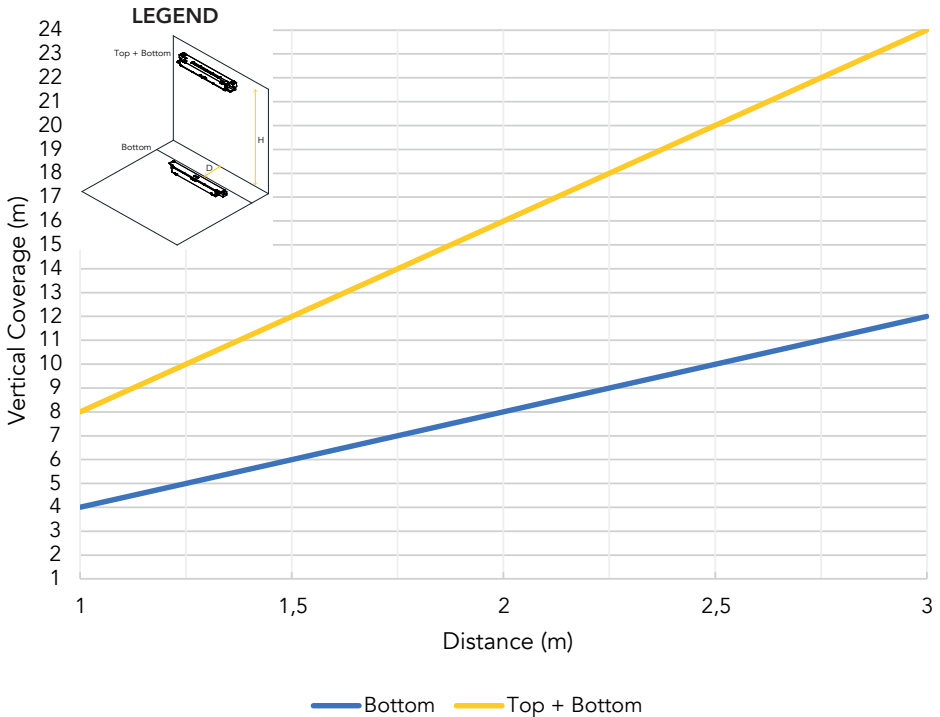

4 - CONNECTION TO THE MAINS SUPPLY

WARNING: For protection from electric shock, the fixture must be earthed!

The product is equipped with auto-switching power supply that automatically adjusts to any 50-60Hz AC power source from 100-240 Volts.

If you need to install a power plug on the power cable to allow connection to power outlets, install a grounding-type (earthed) plug, following the plug manufacturer's instructions. If you have any doubts about proper installation, consult a qualified electrician.

The max power consumption is 400W.

Core (EU)	Core (US)	Connection	Plug terminal marking
Brown	Black	Live	L
Blue	White	Neutral	N
Yellow+green	Green	Earth	

5 - START UP

CONNECT AND DISCONNECT POWER FROM THE PRODUCT

To apply and disconnect power to the product:

- Check that the product is installed and secured as indicated in the Safety Informations, and that personal safety will not be put at risk when the fixture lights up.
- Connect the power connector into the Mains input socket (100-240 VAC-50/60 Hz).
- The product is then ready for its operations and can be controlled through the available input signals on board.
- To disconnect power from the product, disconnect the Mains from the socket.

6 - PRODUCT OVERVIEW

1. USER INTERFACE with display and buttons for access to the control panel functions.
2. ANTENNA of Wireless DMX Receiver internal module.
3. BUTTON FOR ANGLE ADJUSTING: range: ± 8 .
4. BUTTON FOR INSERTING BARN DOOR.
5. ADJUSTABLE RUBBER FEET.
6. POWER IN: for connection to the Mains 100-240V~/50-60Hz.
7. DMX IN (5-p XLR): 1 = GND, 2 = sign-, 3 = sign+, 4 N/C, 5 N/C.
8. EtherCON CONNECTORS IN / OUT signal.
9. MAIN FUSE HOLDER: replace a burnt-out fuse by one of the same type only (T6.3 AL 250 V).
10. POWER OUT: power output for connection of multiple units in series.
11. DMX OUT (5-p XLR): 1 = GND, 2 = sign-, 3 = sign+, 4 N/C, 5 N/C.

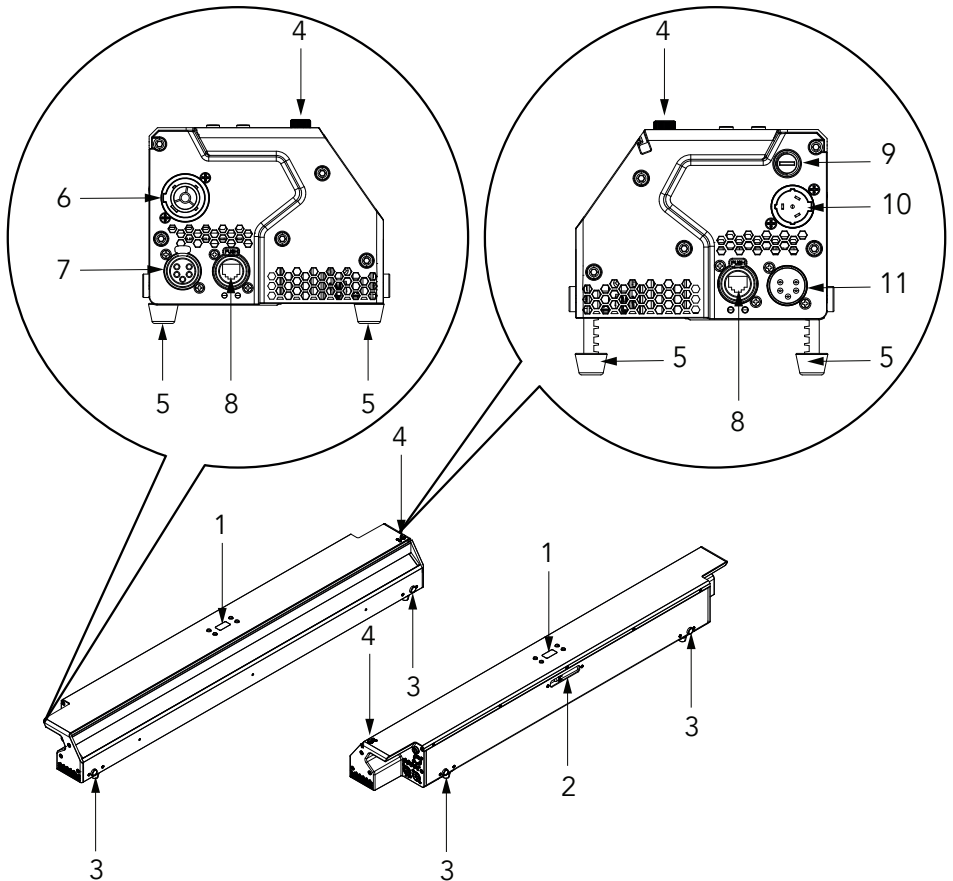

Fig.3

7 - DMX CONNECTION

CONNECTION OF THE CONTROL SIGNAL: DMX LINE

The product has XLR sockets for DMX input and output.
The default pin-out on both socket is as the following diagram:

**DMX - INPUT
XLR plug**



- Pin1 : GND - Shield
- Pin2 : - Signal
- Pin3 : + Signal
- Pin4 : N/C
- Pin5 : N/C

**DMX - OUTPUT
XLR socket**



Fig.4

INSTRUCTIONS FOR A RELIABLE DMX CONNECTION

Use shielded twisted-pair cable designed for RS-485 devices: standard microphone cable cannot transmit control data reliably over long runs. 24 AWG cable is suitable for runs up to 300 meters (1000 ft). Heavier gauge cable and/or an amplifier is recommended for longer runs.
To split the data link into branches, use splitter-amplifiers in the connection line.
Do not overload the link. Up to 32 devices may be connected on a serial link.

CONNECTION DAISY CHAIN

Connect the DMX data output from the DMX source to the product DMX input (male connector XLR) socket.
Run the data link from the product XLR output (female connector XLR) socket to the DMX input of the next fixture.
Terminate the data link by connecting a 120 Ohm signal termination. If a splitter is used, terminate each branch of the link.
Install a DMX termination plug on the last fixture on the link.

CONNECTION OF THE DMX LINE

DMX connection employs standard XLR connectors. Use shielded pair-twisted cables with 120Ω impedance and low capacity.
The following diagram shows the connection mode:

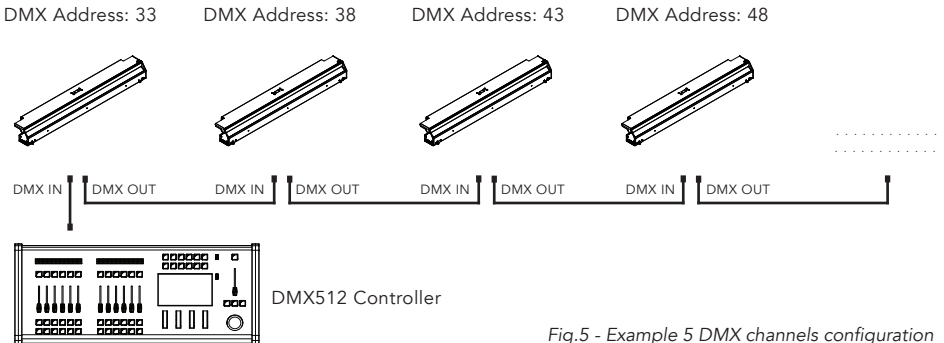

Fig.5 - Example 5 DMX channels configuration

CONSTRUCTION OF THE DMX TERMINATION

The termination is prepared by soldering a 120Ω 1/4 W resistor between pins 2 and 3 of the male XLR connector, as shown in figure.

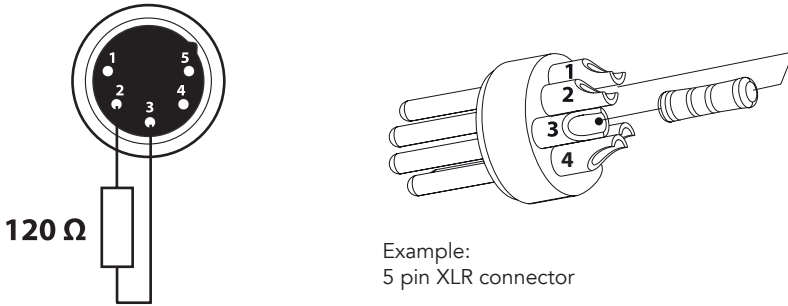

Fig.6

DMX ADDRESSING

In order to start controlling the product via DMX, the first step is to select a DMX address, also known as the start channel, this is the first channel used to receive instructions from a DMX controller. If you wish to control the product individually, it is necessary to assign a different starting address channel to each fixture.

The number of channels occupied from the product depends on the DMX mode selected, so always verify the DMX Mode in the MENU before start addressing.

If you assign two fixtures the same address, they will be executing the same behaviour. Selecting the same address to multiple fixtures can be useful for diagnostic purposes and symmetrical control.

DMX addressing is limited to make it impossible to set the DMX address so high that you are left without enough control channels for the product.

To set the fixture's DMX address:

1. Press MENU to open the main menu.
2. Reach the addressing menu, then select the DMX ADDRESS settings.
3. Select the address from 1 to 512 using the navigation arrows/buttons and confirm by pressing ENTER.
4. Press Menu to exit and return to the Home screen.

ETHERNET CONNECTION

The products is provided with two 8-pin RJ-45 sockets for Ethernet input/output for a simple days chain connection to the network.

The product can be controlled with ArtNet (or others available) communication protocol.

Use a network cable category 5 (with four "twisted" wire pairs) and standard RJ-45 plugs.

ETHERNET OPERATION

Please refer to the section MENU STRUCTURE contained in this document for detailed informations about the parameters of setting on the fixture (Protocol, Net, Subnet, Universe, Start Channel and IP Address, Ethernet to DMX No/Yes).

- About the IP addresses is recommended to set 002.xxx.xxx.xxx or 010.xxx.xxx.xxx.
- The submask net is fixed at 255.0.0.0.

RJ-45 socket (front view):

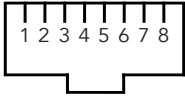

- 1-TD
- 2-TD-
- 3-RX+
- 4-Not connected

- 5-Not connected
- 6-RX-
- 7-Not connected
- 8-Not connected

RJ-45 socket (front view):

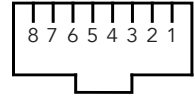

Fig.7

ETHERNET TO DMX OPERATIONS

Please refer to the section MENU STRUCTURE contained in this document for detailed informations. This function allow a product receiving an ethernet signal protocol to re-transmit the incoming signal onto a wired DMX line through its onboard XLR-out connector.

- An Ethernet protocol (Artnet, sACN or others available) has to be enabled from Ethernet menu at first fixture. **Please make sure that wireless receiver is switched to OFF if you use Ethernet communication.**
- Enable the option Ethernet To DMX from the Ethernet menu at the first product (connected to the Ethernet) in the signal chain, next products have standard DMX setting.
- Connect the Ethernet input of the first product in the data chain with the network. Connect the DMX output of this product with the input of the next product until all products are connected to the DMX chain.
- Caution: At the last product, the DMX chain has to be terminated with a terminator. Solder a 120 Ω resistor between Signal (-) and Signal (+) into a XLR-plug and connect it in the DMX-output of the last product.

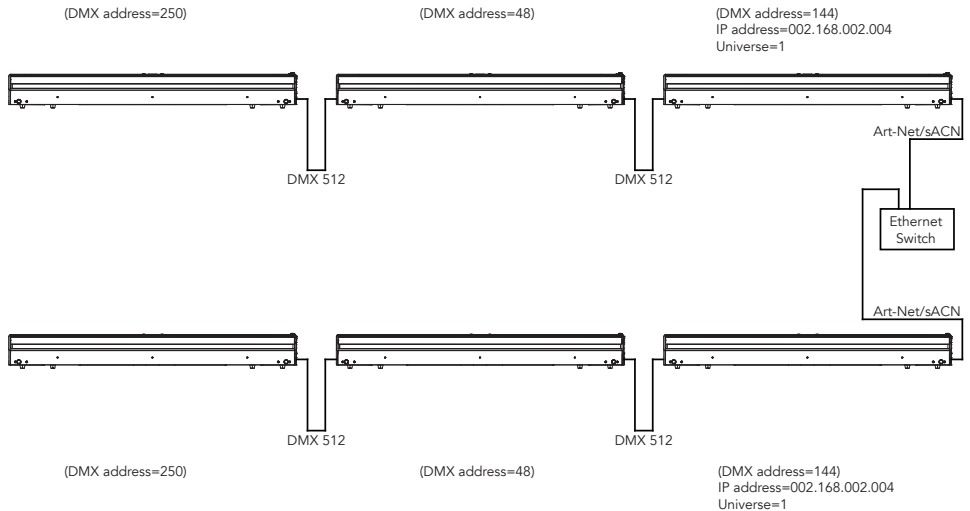

Fig.8 - Example configuration

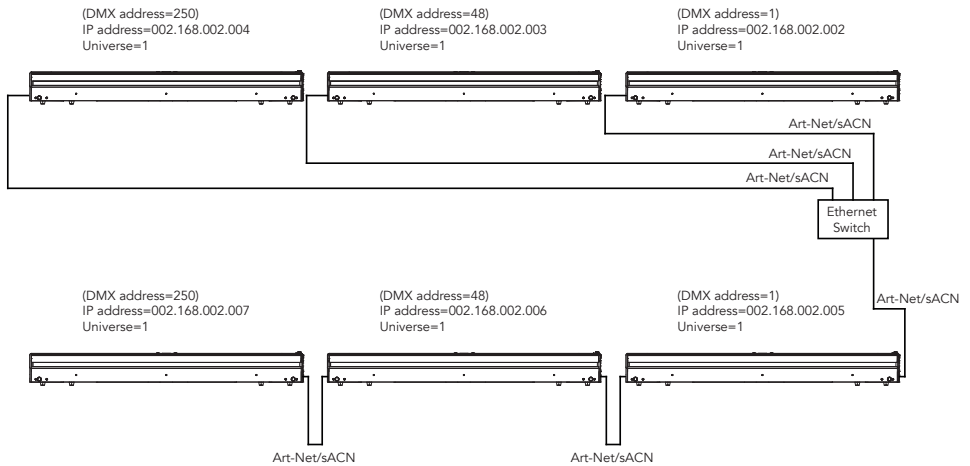

Fig.9 - Example configuration

OPERATION AS A WIRELESS TRANSMITTER

ECLC100 can be used as wireless transmitter for transmit at different wireless receivers DMX or Artnet/sACN signal. To use ECLC100 as wireless transmitter, please follow the procedure below:

1. Push MENU button until you show CONNECT on display, then press ENTER button to confirm.
2. Use UP/DOWN buttons for select Wireless, then press ENTER to confirm.
3. Push ENTER button on WDMX ON/OFF function and enable it to ON.
4. Select WDMX mode and set it on Transmitter (please note that WDMX mode will be available only if WDMX ON/OFF is set to ON).
5. Ensure that the receiver units are not connected to any other transmitter. Please refer to "Reset the receiver" paragraph.
6. Enable TX LINK to ON to link transmitter to receivers (please note that TX LINK will be available only if WDMX mode is set to Transmitter).
 - The transmitter scans for all unlinked receivers for a period of about 5 seconds.
 - If the connection fails, check the position of the receiver.
 - The wireless icon on the receiver display indicates the received signal strength.

Unlinking the transmitter

Follow the procedure below to unlink the transmitter from all receivers connected with the unit.

1. Push MENU button until you show CONNECT on display, then press ENTER button to confirm.
2. Use UP/DOWN buttons for select Wireless, then press ENTER to confirm.
3. Enable TX UNLINK to ON 8 (please note that TX UNLINK will be available only if WDMX mode is set to Transmitter).
 - All connected receivers will be unlinked.

DMX TO WDMX (TX)

This function enable or disable the transmission through wireless of the DMX signal from the transmitter side to the receiver.

NOTE: Artnet and sACN have higher priority on DMX if they are connected to transmitter.

OPERATION AS A WIRELESS RECEIVER

ECLCYC100 can be used as wireless receiver connected to a wireless transmitter.

To use ECLCYC100 as wireless receiver, please follow the procedure below:

1. Push MENU button until you show CONNECT on display, then press ENTER button to confirm.
2. Use UP/DOWN buttons for select Wireless, then press ENTER to confirm.
3. Push ENTER button on WDMX ON/OFF function and enable it to ON.
4. Select WDMX mode and set it on Receiver (please note that WDMX mode will be available only if WDMX ON/OFF is set to ON).
5. Enable RX RESET to ON to reset the receiver (please note that RX RESET will be available only if WDMX mode is set to Receiver).
6. On the transmitter, enable TX LINK to ON to link transmitter to the receivers.
7. If the connection is successful and DMX input is available the display on the receiver unit will show the DMX address. If DMX signal is not available, the display will show "No signal" but keeps the transmitter linked.
8. If the connection fails, check the position of the receiver.
9. The wireless icon on the receiver display indicates the received signal strength.

Reset the receiver

Follow the procedure below to reset the receiver.

1. Push MENU button until you show CONNECT on display, then press ENTER button to confirm.
 2. Use UP/DOWN buttons for select Wireless, then press ENTER to confirm.
 3. Enable RX RESET to ON.
- The wireless icon on the receiver display indicates the received signal strength.

WDMX TO DMX (RX)

This function enable or disable the retransmission of the wireless DMX signal received through the DMX port on the receiver side.

8 - CONTROL PANEL

The product has a display and buttons for access to the control panel functions.

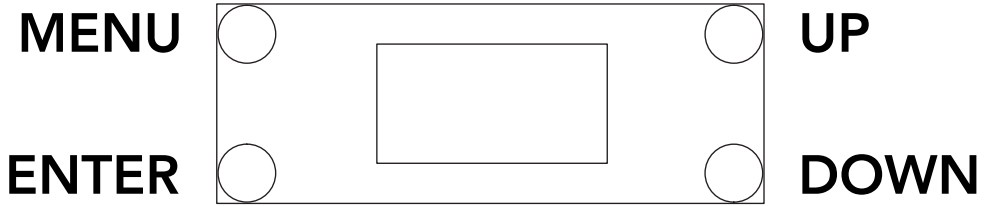

Fig.10

DISPLAY AND BUTTONS LAYOUT

- The product has a display and buttons for access to the control panel functions.
- **MENU**: Used to access the menu tree or to return a previous menu window.
- **UP**: Browse upwards through the menu list and increases the numeric value displayed.
- **DOWN**: Browse downwards through the menu list and decreases the numeric value displayed.
- **ENTER**: Used to confirm the current menu or confirm the current function value or option within a menu.

9 - MENU STRUCTURE

The following chart describes the MENU tree of the product, the terms shown in **BOLD** indicates the default settings.

MENU											
1	CONNECT	DMX Address	Value (001-512)								
		DMX Mode	Theater	1CH	Amber Shift on Color Temperature	2800K 3200K 3500K 4000K 4500K 5000K 5600K 6000K 6500K		Hue (-025+025)			
					Manual Color	Red (000+255) Green (000+255) Blue (000+255) White (000+255) 255					
				2CH	Amber Shift on Color Temperature	2800K 3200K 3500K 4000K 4500K 5000K 5600K 6000K 6500K		Hue (-025+025)			
					Manual Color mixer	Red (000+255) Green (000+255) Blue (000+255) White (000+255)					
				4CH1 5CH 6CH1 10CH1 15CH1 17CH							
				Tour	4Ch 6Ch 10Ch 11Ch 15Ch						
			Wireless	WDMX ON/ OFF	On-Off						Enable/Disable the wireless card.
				WDMX mode	Transmitter Receiver						Allows to choose whether to set the wireless on the Transmitter or Receiver. WDMX mode is unlocked only if WDMX ON / OFF is ON.
				TX link	On-Off						TX link unlock when the unit is set as a transmitter..

		TX unlink	On-Off			Disconnect the transmitter from all receivers. TX unlink unlocks only if WDMX mode is on transmitter.	
		RX reset	On-Off			Total reset of the receiver. RX reset unlocks only if WDMX mode is receiver.	
		DMX to WDMX (TX)	On-Off			Enable/Disable the transmission of the dmx from the transmitter to the receiver via wdmx.	
		WDMX to DMX (RX)	On-Off			Enable/Disable the retransmission of the DMX from the receiver to the other units connected by cable to the receiver itself.	
2	SETUP	Screen	Back Light	On 10 s 20 s 30 s		Back Light - Allows you to select the timing after that display will switch automatically off when unactive.	
			Flip Display	No-Yes		Flip Display - Allows you to rotate the display by 180°.	
			Key Lock	No-Yes		Key Lock - Allows you lock the buttons on the control panel by a password. Press following combinations (password) in order to access to the user menu : UP, DOWN, UP, DOWN, ENTER.	
3	ADVANCED	Full On Mode	HB Studio			HB - High Brightness Mode, delivering the full output on every primary color Studio – Calibrated white output at 6000K,when all primary colors are set to full.	
		Dimmer Mode	Off Dimmer 1 Dimmer 2 Dimmer 3			Linear dimmer behaviour. Dimmer curve adding little fade. Dimmer curve adding medium fade. Dimmer curve adding long fade.	
		Color Calibration	White Balance	Off			Disable the White Calibration at full.
				Adjust	Red (125÷255) Green (125÷255) Blue (125÷255) White (125÷255)		To adjust the max level for each color.
				Calibrated			Manufacturer calibration to grant performance and color consistency.
			Led Frequency	600Hz 1200 Hz 2000 Hz 4000 Hz 6000Hz 25kHz 40kHz			Select PWM frequency.
		Factory Reload	No-Yes			To reset the unit to factory default settings.	
4	INFORMATION	Fixture Time	0÷9999			View informations about product operating lifetime.	
		Disp Version	V1.3				
		NET Version	V1.3				
		UID	15D00228****			To view the ID for the product RDM control.	
5	STAND ALONE	Master/Slave	Master Slave			Allow you to link and operating in synk multiple units without a DMX console. Choose a unit to perform as the Master. This unit must be the first unit in line; Set the successive units to be slave.	
		Effects	Effect 1 Effect 2 Effect 3 Effect 4 Effect 5	Speed 1÷100			

	Static	Fixed color: R G B W RG RB RW GB GW BW RGB RGW RBW GBW RGBW	Dimmer (000÷255)	Select of the following predefined color combination and its Dimmer value. After enabled this mode, the unit will be automatically assigned as Master.
		Color Temperature: 2800K 3200K 3500K 4000K 4500K 5000K 5600K 6000K 6500K	Dimmer (000÷255) Hue (-025÷025)	Select a predefined White CCT output from the list.
		Manual Color Mixer: Red <000-255> Green <000-255> Blue <000-255> White <000-255>	(000÷255) (000÷255) (000÷255) (000÷255)	User generated color preset by assigning values to each primary color attribute. After enabled this mode, the unit will be automatically assigned as Master.

NOTE: If the projector is in Slave mode if the DMX signal is lost, the projector will remain on according to the last received DMX value. If the projector was in STATIC or AUTO mode, if the DMX signal is lost, the projector will return to the previously set STATIC or AUTO.

10 - RDM FUNCTIONS

The product can communicate using RDM (Remote Device Management) protocol over a DMX512 Networks.

RDM is a bi-directional communications protocol for use in DMX512 control systems, it is the open standard for DMX512 device configuration and status monitoring.

The RDM protocol allows data packets to be inserted into a DMX512 data stream without affecting existing non-RDM equipment. It allows a console or dedicated RDM controller to send commands to and receive messages from specific fixtures.

RDM also works via wireless.

The PIDs in the following tables are supported in the product.

Parameter	PID	GET	SET
DEVICE_LABEL	0x0082	x	x
DMX_START_ADDRESS	0x00F0	x	x
DMX_PERSONALITY	0x00E0	x	x
DMX_PERSONALITY_DESCRIPTION	0x00E1	x	
CURVE	0x0343	x	x
CURVE_DESCRIPTION	0x0344	x	
MODULATION_FREQUENCY	0x0347	x	x
MODULATION_FREQUENCY_DESCRIPTION	0x0348	x	
FACTORY_DEFAULTS	0x0090	x	x
Effects (Effects1-5)	0x8209	x	x
Effects Speed (001-100)	0x8210	x	x
Master/Slave (0:Master 1:Slave)	0x8211	x	x
Full_On_Mode (Full On 0:HB 1:Studio)	0x8217	x	x
Manual Color Red(000-255)	0x82C0	x	x
Manual Color Green(000-255)	0x82C1	x	x
Manual Color Blue(000-255)	0x82C2	x	x
Manual Color White(000-255)	0x82C3	x	x
Fix Color (1-15:R,G,B,W...)	0x82BE	x	x
White Preset (1-9:2800K,3200K,3500K...)	0x82BF	x	x

11 - DMX CHARTS

THEATRE

Channel	1 Ch	2 Ch	4 Ch "1"	5 Ch "1"	6 Ch	10 Ch	15 Ch	17 Ch
1	DIMMER	DIMMER	DIMMER	DIMMER	DIMMER	DIMMER	DIMMER	DIMMER
2		DIMMER SPEED	CTO	CTO	CTO	RED	DIMMER FINE	DIMMER FINE
3			HUE	HUE	HUE	GREEN	RED	STROBE
4			DIMMER SPEED	STROBE	STROBE	BLUE	RED FINE	CTO
5				DIMMER SPEED	COLOR MACRO	WHITE	GREEN	HUE
6					DIMMER SPEED	CTO	GREEN FINE	CROSSFADE
7						HUE	BLUE	RED
8						STROBE	BLUE FINE	RED FINE
9						COLOR MACRO	WHITE	GREEN
10						DIMMER SPEED	WHITE FINE	GREEN FINE
11							CTO	BLUE
12							HUE	BLUE FINE
13							STROBE	WHITE
14							COLOR MACRO	WHITE FINE
15							DIMMER SPEED	COLOR MACRO
16								CTO ON COLORS
17								DIMMER SPEED

THEATRE

1 Ch	2 Ch	4 Ch "1"	5 Ch	6 Ch "1"	10 Ch "1"	15 Ch "1"	17 Ch	FUNCTION	DMX Value	Default
1	1	1	1	1	1	1	1	DIMMER 0÷100%	000 ÷ 255	000
						2	2	DIMMER FINE 0÷100%	000 ÷ 255	000
							3	STROBE No Function (shutter open) Strobe effect slow to fast No Function (shutter open) Random strobe effect slow to fast No Function (shutter open)	000 ÷ 030 031 ÷ 100 101 ÷ 130 131 ÷ 200 201 ÷ 255	255
							5	HUE 25 to 0 0 0 to +25	000 ÷ 126 127 ÷ 127 128 ÷ 255	127
					2	3	7	RED 0÷100%	000 ÷ 255	000
						4	8	RED FINE 0÷100%	000 ÷ 255	000
					3	5	9	GREEN 0÷100%	000 ÷ 255	000
						6	10	GREEN FINE 0÷100%	000 ÷ 255	000
					4	7	11	BLUE 0÷100%	000 ÷ 255	000
						8	12	BLUE FINE 0÷100%	000 ÷ 255	000
					5	9	13	WHITE 0÷100%	000 ÷ 255	000
						10	14	WHITE FINE 0÷100%	000 ÷ 255	000
		2	2	2			4	CTO 2800K - 3200K 3200K - 3500K 3500K - 4000K 4000K - 4500K 4500K - 5000K 5000K - 5600K 5600K - 6000K 6000K - 6500K	000 ÷ 031 032 ÷ 063 064 ÷ 095 096 ÷ 127 128 ÷ 159 160 ÷ 191 192 ÷ 223 224 ÷ 255	000
					6	11		CTO 2800K-3200K 3200K-3500K 3500K-4000K 4000K-4500K 4500K-5000K 5000K-5600K 5600K-6000K 6000K-6500K Color Mix	000 ÷ 030 031 ÷ 060 061 ÷ 090 091 ÷ 120 121 ÷ 150 151 ÷ 180 181 ÷ 210 211 ÷ 240 241 ÷ 255	000
		3	3	3	7	12		HUE 0 -25°÷25°	000 ÷ 000 001 ÷ 255	000
							6	CROSSFADE 0÷100%	000 ÷ 255	000
			4	4	8	13	3	STROBE No Function Strobe Slow to Fast	000 ÷ 010 011 ÷ 255	000

				5	9	14	15	COLOR MACRO No Function Amber Shift on Color Macro	000 ÷ 002 003 ÷ 005 006 ÷ 255	000
							16	CTO ON COLORS 0÷100%	000 ÷ 255	000
	2	4	5	6	10	15	17	DIMMER SPEED MODE Preset dimmer speed from display menu Dimmer speed mode off Dimmer speed mode1 (fast speed) Dimmer speed mode2 (middle speed) Dimmer speed mode3 (slow speed)	000 ÷ 051 052 ÷ 101 102 ÷ 152 153 ÷ 203 204 ÷ 255	000

TOUR

Channel	4 Ch "2"	6 Ch "2"	10 Ch "2"	15 Ch "2"
1	RED	DIMMER	DIMMER	DIMMER
2	GREEN	RED	RED	DIMMER FINE
3	BLUE	GREEN	GREEN	RED
4	WHITE	BLUE	BLUE	RED FINE
5		WHITE	WHITE	GREEN
6		STROBE	STROBE	GREEN FINE
7			COLOR TEMPERATURE	BLUE
8			AUTO PROGRAM	BLUE FINE
9			AUTO SPEED	WHITE
10			DIMMER SPEED	WHITE FINE
11				STROBE
12				COLOR TEMPERATURE
13				AUTO PROGRAM
14				AUTO SPEED
15				DIMMER SPEED

TOUR

4 Ch "2"	6 Ch "2"	10 Ch "2"	15 ChB"2"	FUNCTION	DMX Value	Default
	1	1	1	DIMMER 0÷100%	000 ÷ 255	000
			2	DIMMER FINE 0÷100%	000 ÷ 255	000
1	2	2	3	RED 0÷100%	000 ÷ 255	255
			4	RED FINE 0÷100%	000 ÷ 255	255
2	3	3	5	GREEN 0÷100%	000 ÷ 255	255
			6	GREEN FINE 0÷100%	000 - 255	255
3	4	4	7	BLUE 0÷100%	000 ÷ 255	255
			8	BLUE FINE 0÷100%	000 ÷ 255	255
4	5	5	9	WHITE 0÷100%	000 ÷ 255	255
			10	WHITE FINE 0÷100%	000 ÷ 255	000
	6	6	11	STROBE No Function Strobe Slow to Fast	000 ÷ 010 011 ÷ 255	255
		7	12	COLOR TEMPERATURE Color Mix 2800K 3200K 3500K 4000K 4500K 5000K 5600K 6000K 6500K Color Mix	000 ÷ 005 006 ÷ 030 031 ÷ 055 056 ÷ 080 081 ÷ 105 106 ÷ 130 131 ÷ 155 156 ÷ 180 181 ÷ 205 206 ÷ 230 231 ÷ 255	000
		8	13	AUTO PROGRAMS No Function Auto Program 1 Auto Program 2 Auto Program 3 Auto Program 4 Auto Program 5 (Auto Program1-4)	000 ÷ 010 011 ÷ 060 061 ÷ 110 111 ÷ 160 161 ÷ 210 211 ÷ 255	
		9	14	AUTO SPEED Auto speed slow to fast	000 ÷ 255	
		10	15	DIMMER SPEED MODE Preset dimmer speed from display menu Dimmer speed mode off Dimmer speed mode1 (fast speed) Dimmer speed mode2 (middle speed) Dimmer speed mode3 (slow speed)	000 ÷ 051 052 ÷ 101 102 ÷ 152 153 ÷ 203 204 ÷ 255	

12 - ACCESSORIES INSTALLATION

THE POLE OPERATED YOKE (CODE ECLCYC100PO)

The pole operated yoke bracket is available as accessory and it can be mounted from the users, see the following drawing which shows the process for Yoke replacement.

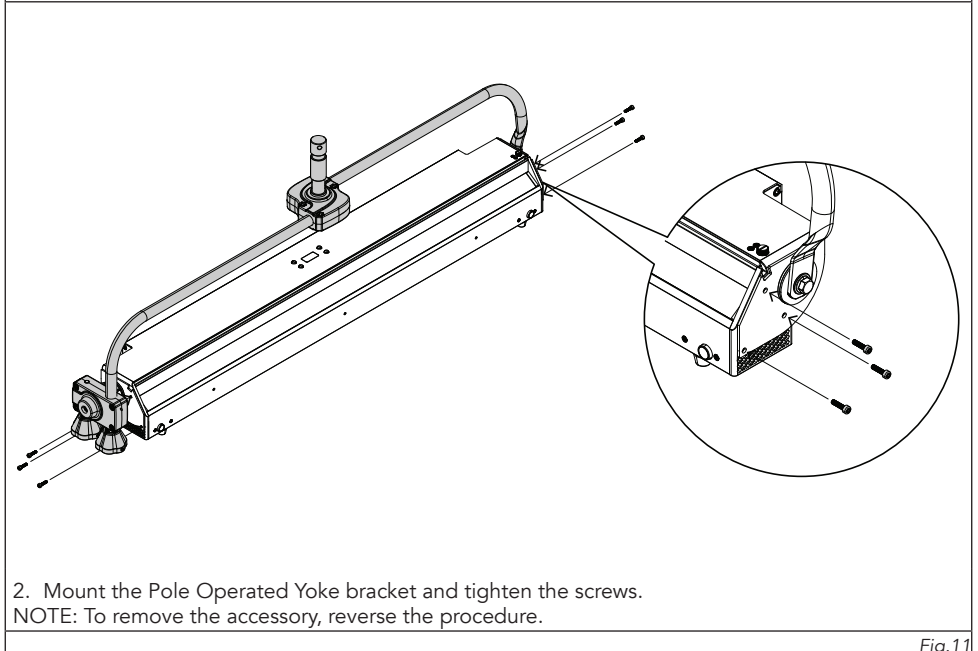
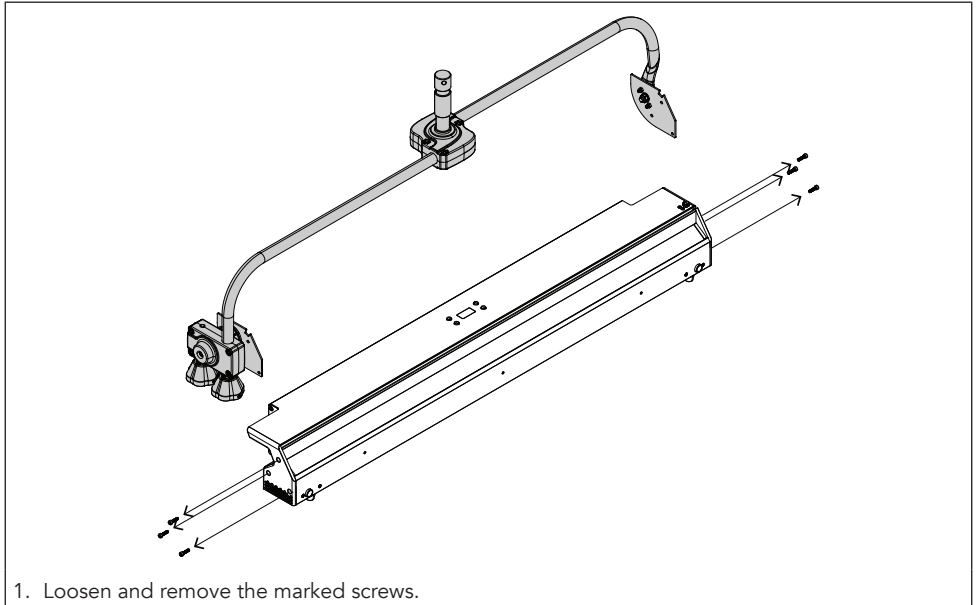
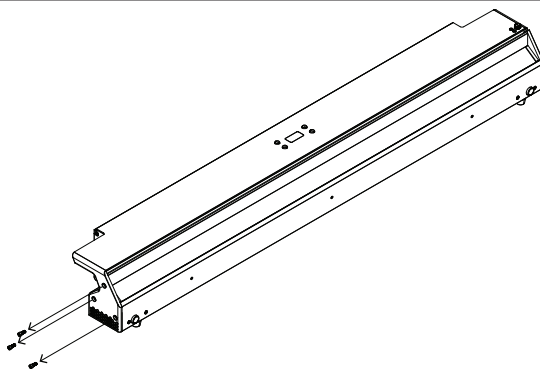

Fig.11

DIFFUSION FILTERS (CODE ECLCYCF)

Light diffuser filter are available as optional accessories.



1. Loosen and remove the marked screws.

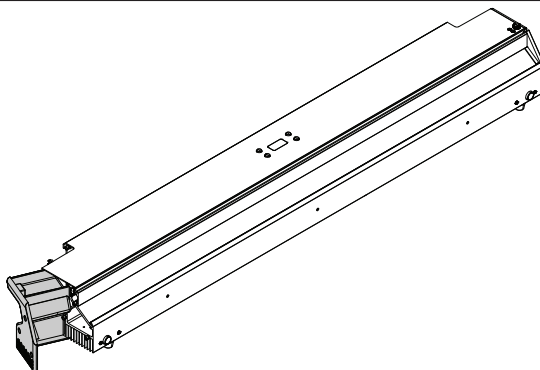

2. Open the side cover.

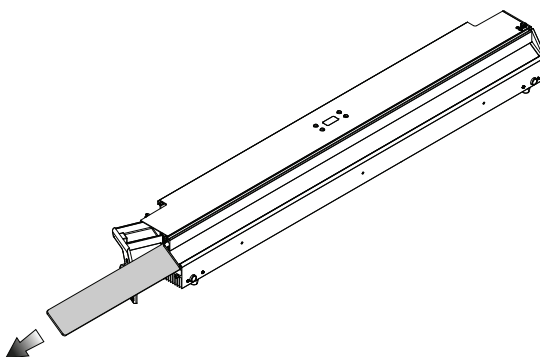

3. Gently remove the filter located under the glass.
4. Insert the desired diffuser filter, always in the same position.
5. Mount the side cover and tighten the screws.

Fig.12

BARN DOOR (CODE ECLCYCBD100)

Upper and lower barndoors with directional flaps to adjust the light beam is available as optional accessory.

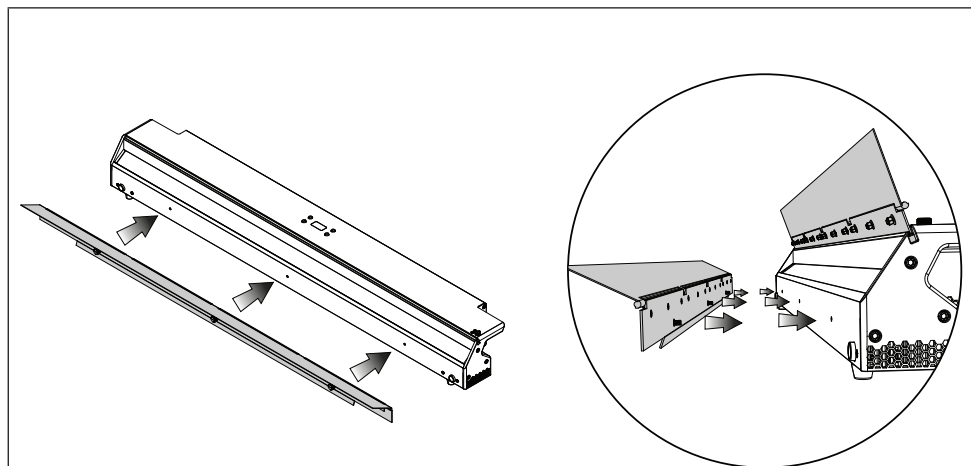

1. Mount the lower barndoor fixing the three screws on the hardware into the holes provided on the front housing of the product. Then tighten the screws through the three knobs of the accessory.
NOTE: To remove the accessory, reverse the procedure.

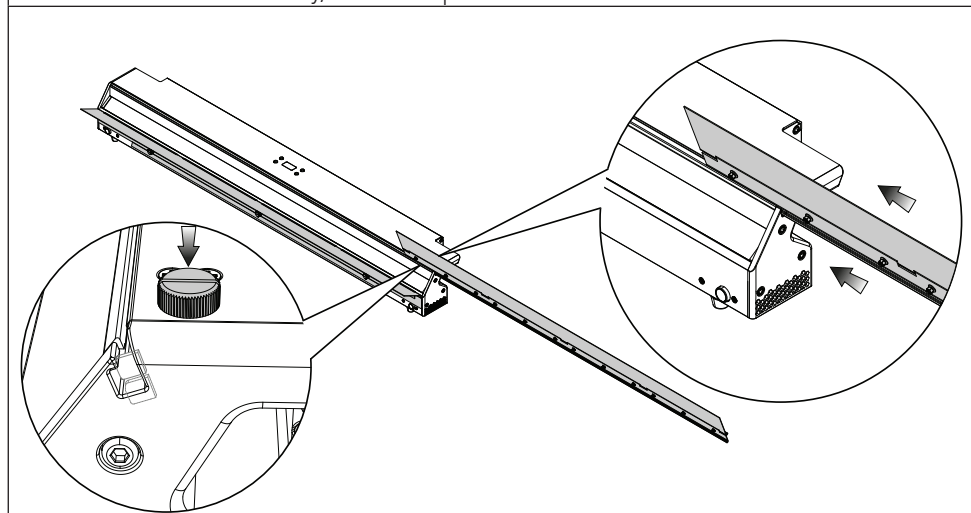

2. To insert the upper door, press the button provided on the top cover to release the lock provided in the slot on the hardware. Then insert the barndoor in the slot.
 3. Adjust the angle of the leaves to focus the beam.
- NOTE: to remove the upper barndoor press the button provided on the top cover to release the lock provided in the slot on the hardware.

Fig.13

HANGING BAR (CODE ECLCYCOHB)

The orientable hanging bar is available as optional accessory.

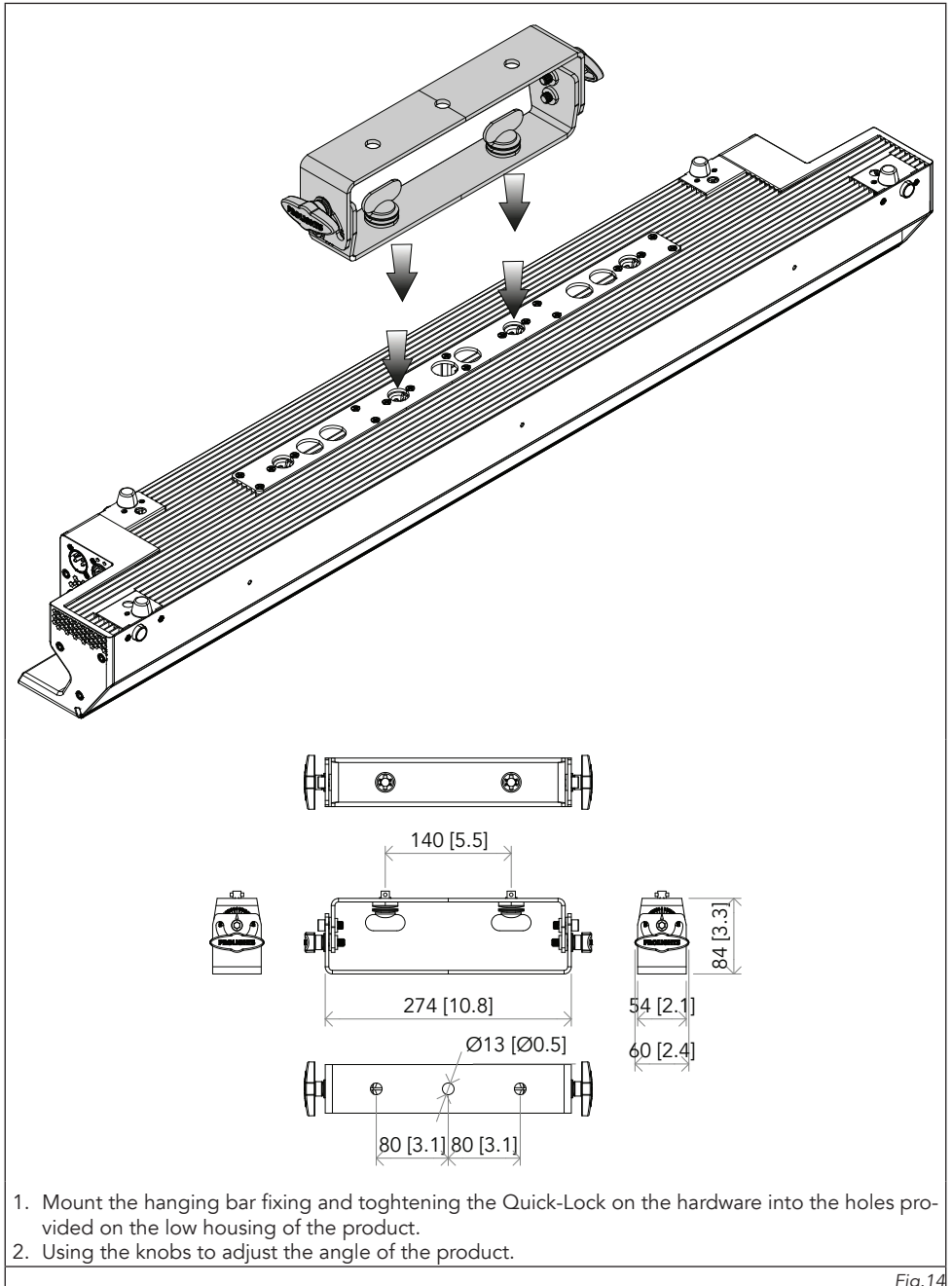

Fig.14

13 - MAINTENANCE

MAINTENANCE AND CLEANING THE PRODUCT

WARNING: Disconnect from the mains before starting any maintenance work

It is recommended to clean the front at regular intervals, from impurities caused by dust, smoke, or other particles to ensure that the light is radiated at maximum brightness.

- For cleaning, disconnect the main plug from the socket. Use a soft, clean cloth moistened with a mild detergent. Then carefully wipe the part dry. For cleaning other housing parts use only a soft, clean cloth. Never use a liquid, it might penetrate the unit and cause damage to it.
- The user must clean the product periodically to maintain optimum performance and cooling. The user may also upload firmware (product software) to the fixture via the DMX signal input port or USB port using firmware and instructions from PROLIGHTS.
- The frequency of such maintenance operations is to be performed according to various factors, such as the amount of the use and the condition of the installation environment (air humidity, presence of dust, salinity, etc.). It is recommended that the product is subject to annual service by a qualified technician for special maintenance involving at least the following procedures:
- General cleaning of internal parts.
- Restoring lubrication of all parts subject to friction, using lubricants specifically supplied by PROLIGHTS.
- General visual check of the internal components, cabling, mechanical parts, etc.
- Electrical, photometric and functional checks; eventual repairs.
- Cleaning the lenses. Only use neutral soap and water to clean the lenses, then dry it carefully with a soft, non-abrasive cloth.

WARNING: the use of alcohol or any other detergent could damage the lenses.

- All other service operations on the product must be carried out by PROLIGHTS, its approved service agents or trained and qualified personnel.
- It is PROLIGHTS policy to apply the strictest possible calibration procedures and use the best quality materials available to ensure optimum performance and the longest possible component lifetimes. However, optical components are subject to wear and tear over the life of the product, resulting in gradual changes in colours over many thousands of hours of use. The extent of wear and tear depends heavily on operating conditions and environment, so it is impossible to specify precisely whether and to what extent performance will be affected. However, you may eventually need to replace optical components if their characteristics are affected by wear and tear after an extended period of use and if you require fixtures to perform within very precise optical and colour parameters.
- Do not apply filters, lenses or other materials on lenses or other optical components. Use only accessories approved by PROLIGHTS.

REPLACING THE FUSE

WARNING: Before replacing the fuse, unplug the product from the mains.

- Remove the old fuse from the housing with a suitable screwdriver (anticlockwise) and replace it with one of the same type and of the same classification (T6.3 AL 250 V).

VISUAL CHECK OF PRODUCT HOUSING

- The parts of the product cover/housing should be checked for eventual damages and breaking start at least every two months. In addition, especially the parts of the front lens holder have to be checked mechanically (by means of movement by the part) if it is firmly fastened to the fixture. If hint of a crack is found on some plastic part, do not use the product until the damaged part will be replaced.
- Cracks or another damages of the cover/housing parts can be caused by the product transportation or manipulation and also ageing process may influence materials.
- This checking is necessary for both fixed installations and preparing product for renting. Any free moving parts inside of the product, cracked cover/housing or any part of front lens not sitting properly in place need to be immediately replaced.

TROUBLESHOOTING

Problems	Possible causes	Checks and remedies
Product doesn't power ON	<ul style="list-style-type: none"> No power to the product. 	<ul style="list-style-type: none"> Check that power is switched ON and cables are plugged in.
	<ul style="list-style-type: none"> Fuse blown or internal fault. 	<ul style="list-style-type: none"> Check if the Fuse is intact and eventually replace it if necessary. Contact the PROLIGHTS Service or authorized service partner. Do not remove parts and/or covers, or carry out any repairs or service that are not described in this Safety and User Manual unless you have both authorization from PROLIGHTS and the service documentation.
Product reset correctly but does not respond correctly to the controller.	<ul style="list-style-type: none"> Bad signal connection. 	<ul style="list-style-type: none"> Inspect connections and cables. Fix eventual bad connections. Repair or replace damaged cables.
	<ul style="list-style-type: none"> Signal connection not terminated. 	<ul style="list-style-type: none"> Insert DMX termination plug in signal output socket of the last product on the signal line.
	<ul style="list-style-type: none"> Incorrect addressing of the product. 	<ul style="list-style-type: none"> Check the product address and control settings.
	<ul style="list-style-type: none"> One of the product is defective and is corrupting the signal transmission on the signal line. 	<ul style="list-style-type: none"> Unplug the XLR in and out connectors and connect them directly together to bypass one product at a time until normal operation is regained. Once found the error, have that fixture serviced by a qualified technician.
Timeout error after fixture reset.	<ul style="list-style-type: none"> One or more hardware components requires mechanical adjustments. 	<ul style="list-style-type: none"> Check product stored error messages for more information. Contact PROLIGHTS Service or an authorized service partner.
Mechanical effect loses position	<ul style="list-style-type: none"> Mechanical hardware require cleaning, adjustment or lubrication. 	<ul style="list-style-type: none"> Check product stored error messages for more information. Contact PROLIGHTS Service or an authorized service partner.
Light output turn OFF Intermittently	<ul style="list-style-type: none"> Fixture is too hot. 	<ul style="list-style-type: none"> Check product stored error messages. Allow product to cool. Clean the product and airflow filters. Reduce ambient temperature.
	<ul style="list-style-type: none"> Hardware failure (temperature sensor, fans, Light source...). 	<ul style="list-style-type: none"> Check product stored error messages for more information. Contact PROLIGHTS Service or an authorized service partner.
General low light intensity	<ul style="list-style-type: none"> Dirty lens assembly. 	<ul style="list-style-type: none"> Clean the fixture regularly.
	<ul style="list-style-type: none"> Dirty or damaged filters. 	<ul style="list-style-type: none"> Install lens assembly properly.

Contact an authorized service center in case of technical problems or not reported in the table can not be resolved by the procedure given in the table.



PROLIGHTS is a trademark of
MUSIC & LIGHTS S.r.l.
musiclights.it

Via A.Olivetti snc
04026 - Minturno (LT) ITALY
Tel: +39 0771 72190

prolights.it
support@prolights.it