

6 5 4 3 2 1

D

D

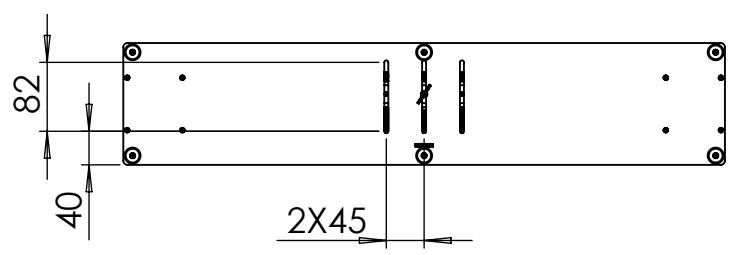
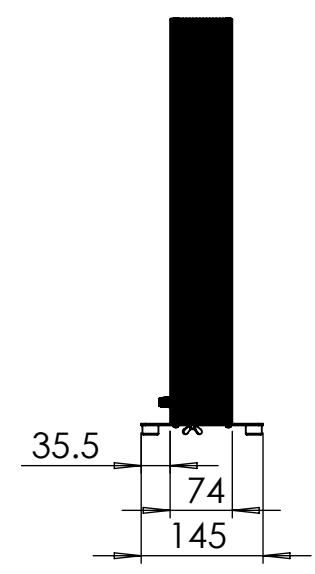
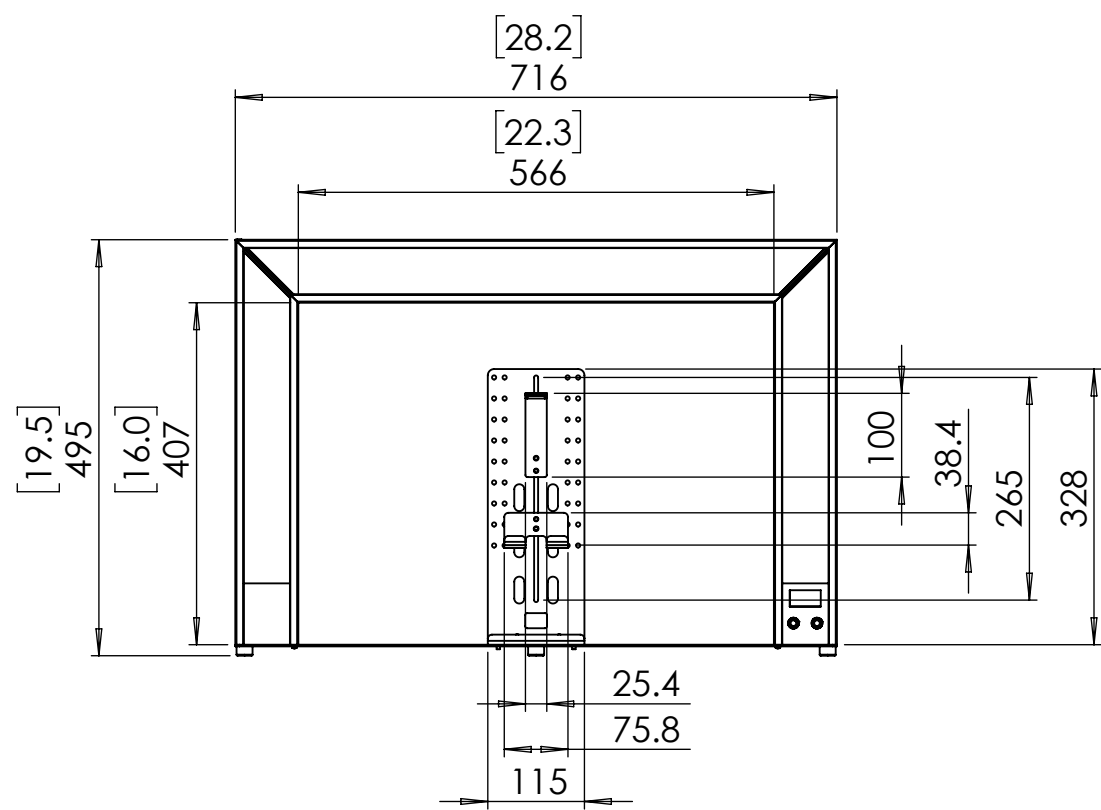

B

B

A

A

6 5 4 3 2 1



ALL INFORMATION CONTAINED IN THIS DOCUMENT IS
PROPERTY OF CHROMA-Q AND MAY NOT BE
REPRODUCED IN WHOLE OR PART WITHOUT
PERMISSION OF CHROMA-Q

UNLESS OTHERWISE SPECIFIED ALL
DIMENSIONS ARE IN MM [INCHES]

TITLE:
SANDI 1622 LINE DRAWING

THIRD ANGLE PROJECTION

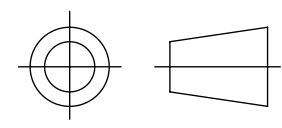

SIZE A4	PART NO. 1518-1000	REV A
-------------------	------------------------------	-----------------

SCALE: 1:10	WEIGHT:	SHEET 2 OF 4
-------------	---------	--------------